

Specifications

Port Sizes	1¼", 1½", 2"
Thread Styles	NPT, BSPT, BSPP
Flow Capacity	300/400/700 SCFM @ 100 PSI
Filter Capacity	0.01 micron & larger
Differential Pressure	< 2.5 PSID at rated flow
Max. Temp./Pressure (Aluminum Bowl)	175 ° F/200 PSIG
Approx. Weight (lb.)	58.0/60.0/64.0
ISO Class	1 Particulate/Oil

For higher pressure applications, consult factory. Units equipped with differential pressure indicator have max. temperature and pressure of 125 ° F and 150 PSIG, regardless of bowl material.



Water
Dirt
Oil
Oil Vapor
Odor

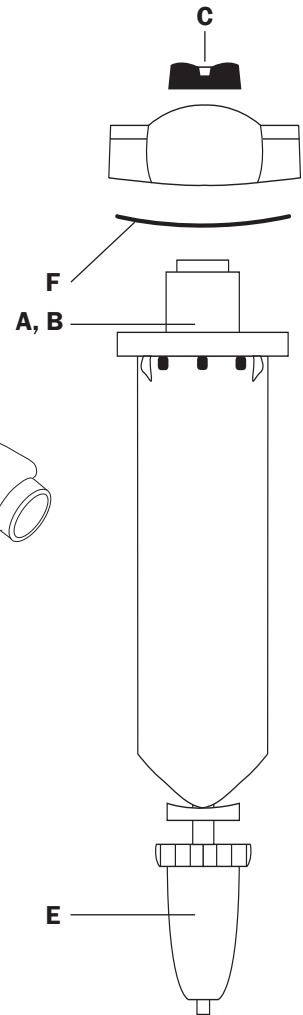

Replacement Parts & Accessories

Description	Part Number
A Replacement Element, 1st Stage	1M-300/1M-400/1M-700
B Replacement Element, 2nd Stage	3C-300/3C-400/3C-700
C Differential Pressure Indicator	N32-W1-DPi
C Blanking Cap (Cover for Indicator)	N32-95-020
D Manual Petcock Drain, Ball Valve	BV-051
E External Automatic Float Drain	N32-95-XD8
F Bowl O-ring	N32-F35-OR

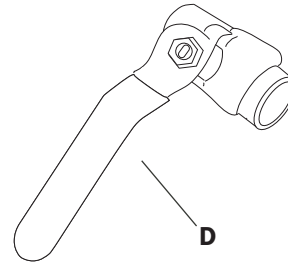

Order Guide

	Port Size	Model Number			Dimensions (in.)		
		Low Flow	Med Flow	High Flow	Height*	Width	Depth
Manual Drain	1¼"	1M-300-M10-DCP	1M-400-M10-DCP	1M-700-M10-DCP	28.0	16.5	7.8
	1½"	1M-300-M12-DCP	1M-400-M12-DCP	1M-700-M12-DCP	28.0	16.8	7.8
	2"	1M-300-M16-DCP	1M-400-M16-DCP	1M-700-M16-DCP	28.0	17.0	7.8
External Automatic Drain	1¼"	1M-300-M10-DC	1M-400-M10-DC	1M-700-M10-DC	32.0	16.5	7.8
	1½"	1M-300-M12-DC	1M-400-M12-DC	1M-700-M12-DC	32.0	16.8	7.8
	2"	1M-300-M16-DC	1M-400-M16-DC	1M-700-M16-DC	32.0	17.0	7.8

*To add an indicator, add "i" to end of model number (Indicator adds about 1" to height)