

# Specifications

<b>Port Sizes</b>	1/4", 3/8"
<b>Thread Styles</b>	NPT, BSPT, BSPP
<b>Flow Capacity</b>	20 SCFM @ 100 PSI
<b>Filter Capacity</b>	0.01 micron & larger
<b>Differential Pressure</b>	< 5.0 PSID at rated flow
<b>Max. Temp./Pressure (Aluminum Bowl)</b>	175 °F/200 PSIG
<b>Max. Temp./Pressure (Polycarbonate Bowl)</b>	125 °F/150 PSIG
<b>Approx. Weight (lb.)</b>	4.0
<b>ISO Class</b>	1 Particulate/Oil

For higher pressure applications, consult factory. Units equipped with differential pressure indicator have max. temperature and pressure of 125 °F and 150 PSIG, regardless of bowl material.



**Water**  
**Dirt**  
**Oil**  
**Oil Vapor**  
**Odor**

# Replacement Parts & Accessories

Description	Part Number
<b>A</b> Replacement Element, 1st Stage	3P-020
<b>B</b> Replacement Element, 2nd Stage	3C-020
<b>C</b> Differential Pressure Indicator	N32-W1-DPi
<b>C</b> Blanking Cap (Cover for Indicator)	N32-95-020
<b>D</b> Bowl Assembly: Metal Bowl, Manual Petcock Drain, & O-ring	N32-95-178
<b>D</b> Bowl Assembly: Metal Bowl, Auto Float Drain, & O-ring	N32-95-950
<b>E</b> Bowl Assembly: Poly Bowl, Manual Petcock Drain, & O-ring*	N32-15-159
<b>E</b> Bowl Assembly: Poly Bowl, Auto Float Drain, & O-ring*	N32-15-160
<b>F</b> Manual Petcock Drain	N32-95-182
<b>G</b> Automatic Plastic Float Drain (Metal Bowl)	N32-95-973
<b>H</b> Bowl O-ring	N32-95-009

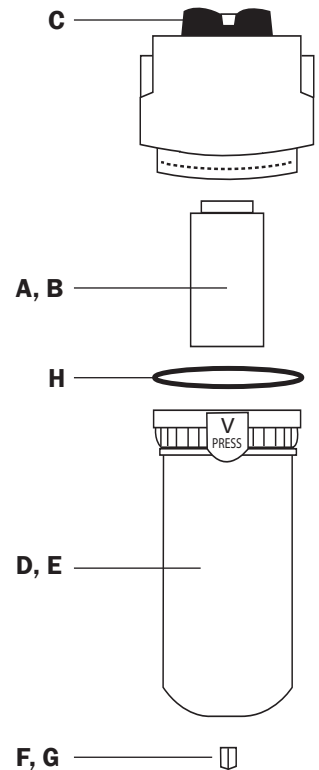

# Order Guide

	Port Size	Model Number		Dimensions (in.)		
		Metal Bowl	Poly Bowl	Height**	Width	Depth
<b>Manual Drain</b>	1/4"	3P-020-M02-DCP	3P-020-P02-DCP	7.2	6.4	2.7
	3/8"	3P-020-M03-DCP	3P-020-P03-DCP	7.2	6.4	2.7
<b>Auto Drain</b>	1/4"	3P-020-M02-DC	3P-020-P02-DC	7.4	6.4	2.7
	3/8"	3P-020-M03-DC	3P-020-P03-DC	7.4	6.4	2.7

\*Poly bowls come with metal bowl guard  
\*\*To add an indicator, add "I" to end of model number (Indicator adds about 1" to height)