

# Specifications

|   |                          |
|---|--------------------------|
| <b>Port Sizes</b>                               | 1/4"                     |
| <b>Thread Styles</b>                            | NPT, BSPT, BSPP          |
| <b>Flow Capacity</b>                            | 20 SCFM @ 100 PSI        |
| <b>Filter Capacity</b>                          | 0.01 micron & larger     |
| <b>Differential Pressure</b>                    | < 1.5 PSID at rated flow |
| <b>Max. Temp./Pressure (Aluminum Bowl)</b>      | 175 °F/200 PSIG          |
| <b>Max. Temp./Pressure (Polycarbonate Bowl)</b> | 125 °F/150 PSIG          |
| <b>Approx. Weight (lb.)</b>                     | 2.0                      |
| <b>ISO Class</b>                                | 1 Particulate/Oil        |

For higher pressure applications, consult factory. Units equipped with differential pressure indicator have max. temperature and pressure of 125 °F and 150 PSIG, regardless of bowl material.



Water  
Dirt  
Oil  
Oil Vapor  
Odor

# Replacement Parts & Accessories

| Description  | Part Number |
|--|-------------|
| <b>A</b> Replacement Element                                       | 3C-020      |
| <b>B</b> Differential Pressure Indicator                           | N32-W1-DPi  |
| <b>B</b> Blanking Cap (Cover for Indicator)                        | N32-95-020  |
| <b>C</b> Bowl Assembly: Metal Bowl, Manual Petcock Drain, & O-ring | N32-95-178  |
| <b>C</b> Bowl Assembly: Metal Bowl, Auto Float Drain, & O-ring     | N32-95-950  |
| <b>D</b> Bowl Assembly: Poly Bowl, Manual Petcock Drain, & O-ring* | N32-15-159  |
| <b>D</b> Bowl Assembly: Poly Bowl, Auto Float Drain, & O-ring*     | N32-15-160  |
| <b>E</b> Manual Petcock Drain                                      | N32-95-182  |
| <b>F</b> Automatic Plastic Float Drain                             | N32-95-973  |
| <b>G</b> Bowl O-ring   | N32-95-009  |

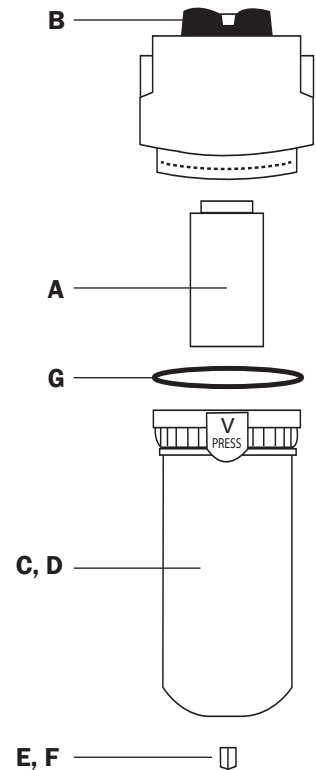

# Order Guide

|                     | Port Size | Model Number |              | Dimensions (in.) |       |       |
|---------------------|-----------|--------------|--------------|------------------|-------|-------|
|                     |           | Metal Bowl   | Poly Bowl    | Height**         | Width | Depth |
| <b>Manual Drain</b> | 1/4"      | 3C-020-M02-P | 3C-020-P02-P | 7.6              | 3.0   | 2.7   |
| <b>Auto Drain</b>   | 1/4"      | 3C-020-M02-F | 3C-020-P02-F | 7.8              | 3.0   | 2.7   |

\*Poly bowls come with metal bowl guard

\*\*To add an indicator, add "i" to end of model number (Indicator adds about 1" to height)